

Inside this issue

ANZCCART'S 20th Anniversary	1
Changes in the Board	1
Office Relocation	2
ANZCCART Conference 2007	2
Revision of the ANZCCART Publication "Euthanasia of Animals Used for Scientific Purposes"	2
Publication of Scientific Papers in ANZCCART News	3
Australia and United Kingdom agree to cooperate on veterinary medicines regulations	3
News from Overseas:	3
• Russell and Burch Announcement	
Managing a Colony of Spiny Mice (<i>Acomys cahirinus</i>) for Perinatal Research	4
6th World Congress on Alternatives and Animal Use in the	11

ANZCCART's 20th Anniversary

This year marks the 20th Anniversary of the formation of the Australian Council for the Care of Animals in Research and Teaching (ACCART) and while there have been a number of changes to this organization and the manner in which it operates, it is still as vital and relevant today as it was when it was formed. Undoubtedly the most significant change that has occurred during that time was in 1994 when the Royal Society of New Zealand accepted an invitation from the ACCART Board to join the organization and our operations were expanded to include the interests of New Zealand ethicists, researchers, teachers and general public. This event was reflected in a change of name and we become known as ANZCCART. The importance of recognizing that we are operating as a part of the global community is no less diminished today and while there are no current plans for ANZCCART that might result in such monumental change, we do continue to monitor relevant events, trends and information from around the World as well as being an active participant in many international meetings.

Within that framework, it is vital that we remember that our principal focus is and must always be in Australia and New Zealand. So, to ensure that ANZCCART remains relevant and a useful resource for you and your colleagues, we are offering you the opportunity to have a say in setting the ANZCCART agenda for the future. If you think there are problems that we can look at, areas where more or better

advice is required, workshops that you would like to see organised or issues that need to be discussed in any areas that fall under the ANZCCART mission, the ANZCCART Board of Management would like to offer this opportunity for you to provide feedback, advice, constructive criticisms or suggestions about what we do and how we do it. This may range from topics for future FACT sheets through to suggestions for future workshops and conferences. Please email ideas or suggestions to ANZCCART@adelaide.edu.au or send them by post or fax (08 8303 7587) at any time.

Changes in the Board of ANZCCART

There have been two important changes on ANZCCART's Board of management this year. Both Professor Julie Owens (ARC Representative) and Professor Roger Dean (AVCC representative) have recently completed their terms of office and stepped down from the Board.

Professor Julie Owens, Head of the School of Obstetrics and Gynaecology, the University of Adelaide served as Director on the Board of ANZCCART from January 2004 and was appointed Chairperson in December 2004. Professor Roger Dean, President and Vice-Chancellor of the University of Canberra served on the Board since September 2004 and was appointed Deputy Chair in December 2005.

Professor Owens has now been replaced on the Board as the ARC Representative by Associate Professor Jeff Schwartz. Associate Professor Schwartz is Laboratory Head and Lecturer in the School of Molecular and Biomedical Sciences at the University of Adelaide and is also a current member of the ARC College of Experts.

Professor Dean has now been replaced on the Board as the AVCC Representative by Professor Lee Astheimer. In January 2006, Professor Astheimer was appointed Pro Vice-Chancellor (Research) at the University of Wollongong after serving 13 years in the Faculty of Health and Behavioural Sciences at the University.

We look forward to a long and productive association with Professor Astheimer and Associate Professor Schwartz on the Board of ANZCCART and thank both Professor Owens and Professor Dean for their invaluable support and contribution during their time on the Board.

Relocation of ANZCCART Office

The ANZCCART Office will shortly be moving from our current accommodation in the Mitchell Building on the University of Adelaide's North Terrace Campus to the University's Research Park, Thebarton. The University of Adelaide is currently undergoing major building works and ours is one of many offices that have been relocated.

The Thebarton Campus is 4km west of the City and is located on the banks of the Torrens River. Once the site of the old Fauldings Pharmaceuticals factory, the campus has been redeveloped as a research park and is a vital link between the University of Adelaide and Australian business and industry. The surrounding area has also undergone a period of fairly rapid development over recent years with a large Biotechnology precinct having been set up immediately adjacent to the University's Thebarton campus

The street address of our new office is Suite 19, Level 1, 30-32 Stirling Street, Thebarton. However, our mailing address will remain the same, that is:

ANZCCART
C/o The University of Adelaide,
South Australia, 5005.

Our telephone, fax numbers, email address and internet address will not be affected by this move.

ANZCCART Conference 2007

The theme for this year's ANZCCART conference is "Getting it Right" and will focus on improving knowledge of current anaesthetic and analgesic regimens as well as looking at some governance issues associated with wildlife studies, animal use statistics and the triennial review system of AEC operations that came in with the 7th edition of the *Australian Code of Practice for the Care and Use of Animals For Scientific Purposes*.

The Keynote speaker for this year's conference will be Professor Paul Flecknell, Director of the Comparative Biology Centre at the University of Newcastle, Newcastle upon Tyne, UK. Professor Flecknell is widely regarded as the world's leading expert on identifying and managing pain in laboratory animals and is the author or co-author of a number the widely cited books including "*Laboratory Animal Anaesthesia*" and "*Pain Management in Animals*". For more than 25 years, Paul Flecknell has attempted to make life less painful for laboratory animals by bringing them better analgesia and anaesthesia and today, his work is cited in nearly every paper that discusses pain in laboratory animals.

The Conference is being held in Melbourne, Australia from 10 to 12 July. Please check the website www.adelaide.edu.au/ANZCCART for updates.

Revision of the ANZCCART publication "Euthanasia of Animals used for Scientific Purposes".

Since this booklet was first published, it has been regarded as the "gold standard" by which Animal Ethics Committees judge the content of applications they assess and widely cited as one of the authoritative works in this area around the world. The current (second) edition was published in 2001 and a number of things have changed since that time, such as the Australian Code of Practice for the Care and use of Animals for Scientific Purposes (now in its 7th edition) and the availability of some reagents cited in this text and the natural progression that is part of technical refinements intrinsic in our system.

Accordingly, ANZCCART is planning a revision of the text and will publish the third edition of Euthanasia of Animals used for Scientific Purposes in late 2007.

As part of the process of revising or if necessary expanding the text, we welcome comments from all interested parties. Please use this opportunity to bring to our attention your ideas that may address particular

areas in need of revision or preservation and please feel free to highlight what you see as strengths, weaknesses, omissions or areas where you feel the current edition is not adequate to address questions or issues relevant to your work or your interests.

Your ideas and suggestions can be emailed to us at ANZCCART@adelaide.edu.au and we would like to receive them as soon as possible.

Publication of Scientific Papers in ANZCCART News

ANZCCART News is expanding the base of information that is currently being provided to its readers and has started to accept appropriate scientific papers for publication. For editorial purposes, we will define appropriate as indicating a high standard of scientific endeavour that is consistent with the stated goal of ANZCCART – including strict adherence to the principles of the 3Rs.

All papers submitted to ANZCCART will have to be peer reviewed before we can consider accepting them for publication, with the normal standards and requirements of internationally recognised scientific journals being applied.

The first paper to be published in this series is to be found in this edition and has been submitted by a researcher from Monash University in Melbourne. This paper describes a specific desert mouse model, the spiny mouse (*Acomys cahirinus*), which gives birth to more mature infants potentially making it a more appropriate model than convention rodent species for conducting perinatal research.

If you would like to submit an article to be published in ANZCCART News please email to ANZCCART@adelaide.edu.au

Australia and United Kingdom agree to cooperate on veterinary medicines regulations

Two of the world's major pesticide and veterinary medicine regulators, the Australian Pesticides and Veterinary Medicines Authority (APVMA) and the United Kingdom Veterinary Medicines Directorate (UKVMD), have signed an agreement which will allow information and expertise to be shared between the two countries.

The Parliamentary Secretary to the Minister for Agriculture, Fisheries and Forestry, Sussan Ley, said the APVMA had signed similar agreements in the last three years with its counterpart regulators in Canada, the USA and New Zealand.

"This latest agreement with the UKVMD mirrors an agreement reached with the UK Pesticides Safety Directorate in 2006.

"The APVMA and the UKVMD are both respected international regulators of veterinary medicines and this agreement establishes a strong framework for cooperation between the two agencies," Ms Ley said.

"I congratulate Professor Steve Dean and Dr Joe Smith, the respective heads of the UKVMD and APVMA, on the signing of the agreement, which will increase the efficiency and effectiveness of both organisations.

Similar cooperation between the APVMA and its other overseas counterparts is already yielding measurable benefits arising from the sharing of information and collaboration on technical assessments. Currently the APVMA is cooperating with other regulators in Europe and North America to share the simultaneous evaluation of three new agricultural chemicals which will ultimately benefit Australian agriculture.

"Through bilateral cooperation, and participating in OECD work sharing activities, the APVMA is bringing real benefits in both efficiency and quality to veterinary medicines regulation in Australia," Ms Ley said.

"This is the way to stay at the forefront of international best practice, to adopt consistent approaches and to provide timely responses to issues of mutual interest worldwide."

News from Overseas

Russell and Burch Award

The Humane Society of the United States is now accepting nominations for the 2007 Russell and Burch Award, to be presented at the 6th World Congress in Tokyo, Japan. Nominations will be accepted until March 31, 2007.

For details on the award, see the announcement and attachment on the ANZCCART Home Page.

Managing a Colony of Spiny Mice (*Acomys cahirinus*) for Perinatal Research

Hayley Dickinson¹ and David W Walker²

¹Monash Immunology & Stem Cell Laboratories,
and ²Department of Physiology, Monash University

1. Spiny mouse (*Acomys cahirinus*)

The spiny mouse (*Acomys cahirinus*) is a nocturnal rodent species native to regions of Egypt and Israel, where it inhabits sandy deserts and rocky terrains (1). Spiny mice are ideal as a rodent model for perinatal research as they have a relatively long gestation (38-39 days), small litter size (1-5, usually 2-3) and precocial pups (covered with fur and capable of moving around and self-feeding soon after birth). At birth newborn spiny mice weigh approximately 5.5g (2), have a fur coat, open eyes and ears, and are capable of locomotion and thermoregulation due to their advanced sensory and motor capabilities (3). Self-feeding begins within a few days of birth (4), weaning occurs at 2-3 weeks and sexual maturity is reached at approximately 2 months (5). Young adult spiny mice (non-pregnant) weigh approximately 35-40g and older (>2 years old) spiny mice weigh 50-60g. Both wild and captive spiny mice have a life-span of 3-4 years (1 and Dickinson, unpublished observations).

Spiny mice have been studied extensively as models of mature-onset or chemically-induced diabetes and obesity in humans (6-12). They have been used to examine the role of odour and pheromones in maternal, paternal and neonatal behaviours (13, 14). Spiny mice have been used as a small, rodent-like model of precocial development for comparison with altricial (naked, blind and incapable of moving around soon after birth) rodents, such as rats (15-20). We and others have shown that in the spiny mouse the development of the kidney (2), liver (19), lung (20) and various brain regions (15, 16, 21), is essentially completed by the time of birth, unlike other rodents such as the house mouse and rat where significant development and maturation continues for weeks into the neonatal period. We have therefore proposed that the spiny mouse model is a more appropriate, refined model for research into pregnancy and foetal development, and could replace many studies that have used altricial rodent species for investigation of important issues relating to human pregnancy and birth.

In 2001 we imported 11 Spiny Mice to Monash University from an existing colony at the University of Amsterdam (kindly donated by Prof Wouter H. Lamers) that was to be closed down. As there are few colonies of these interesting animals world-wide (and, to our knowledge, no others in the Southern Hemisphere), in this article we document conditions and requirements for successfully maintaining a colony, and briefly describe some area of work where their use may be seen as a refinement when compared with more conventional mouse models.

2. Basic conditions required for health and breeding

2.1 Temperature & light cycle

Spiny mice breed year round in the laboratory if the room temperature is set at 25°C, 30-50% humidity with a 12hr light-dark cycle.

2.2 Diet & water

The spiny mice are fed a diet of standard rat and mouse pellets (Speciality Feeds, WA, Australia) supplemented with fresh carrots and celery once a week. As desert species they are adept at absorbing water from such sources. Snails are one of their major sources of water in the wild (22).

It is important to avoid foods high in fat, such as seeds and nuts as many studies have shown a high rate of obesity and diabetes in spiny mice when their diet includes such supplements (11). Indeed, such a diet can be used to induce obesity in this species.

2.3 Environmental enrichment & male aggression

All spiny mice that are not prescribed breeders (i.e., not specifically for maintenance of colony numbers), are kept in same sex cages of 2-6 animals. Spiny mice are particularly active and inquisitive and, as for any animal kept under laboratory conditions, environmental enrichment is important. For this reason, we include small cardboard boxes and tubes

in their cages and house the spiny mice in high topped rat boxes to allow room for jumping and climbing. They are social animals and usually prefer to be housed in small groups. Occasionally males caged together become aggressive and attack each other, often losing parts of their tails, ears, or chunks of fur. The most aggressive, dominant male can often be identified as the one least affected by such injuries, and it is not usual for this aggressive behaviour to reduce over time. Such males also tend to be cunning and take any opportunity to escape, and if not required for any specific purpose, they should be removed from the colony using an approved culling method.

2.4 Cannibalism

Cannibalism of pups is a normal part of rodent life and happens regularly within a spiny mouse colony. It is a matter of survival of the fittest. If there is a smaller pup in a litter that is unlikely to survive, the mother will eat it. Presumably, this gives the mother more nutrients to pass to the remaining pups. It is not uncommon for an entire litter of pups to be cannibalised by the mother or father. This is more likely to occur with the first litter than it is with subsequent litters; but it can occur at any stage.

3. Handling spiny mice

Spiny mice should not be routinely lifted by their tail, as done with conventional rodents, because the skin at the base of the tail is easily broken, and the entire tail is easily de-sheathed exposing the muscles and blood supply of the tail; unlike lizards, the tail does not repair itself. A spiny mouse can be picked up by cupping it in gloved hands or by encouraging it into a cardboard roll then cupping both hands over the ends of the roll and then transporting it. For actions such as sexing the mice, it is best to capture them by this method and relocate them to a clear plastic container. While their weight is supported, the tail can be lifted to allow observation of the ano-genital region. For the purpose of injections, the spiny mouse can be scruffed, i.e. held by the scruff of the neck. This is best achieved by again placing the animal in a plastic container and putting a thin towel over the spiny mouse. The neck can be carefully scruffed through the towel and the animal placed in the supine position. The other hand is then free to inject. This is not a particularly comfortable position for the spiny mice, and so should not be maintained for longer than 30 seconds.

3.1 Escapees

As previously mentioned spiny mice are very inquisitive and will take any opportunity to explore

the environment beyond the perimeter of the cage. A small gap in cage wiring or a cage left open even for a brief moment is all it takes to have spiny mice running around the room. They will chew just about anything, including cables, boxes, and equipment, these are best kept off the floor and preferably stored within strong plastic boxes.

Pups that have been returned to their home cage after escaping must be carefully monitored, particularly if they are still quite young. An extended period of absence from the home cage significantly changes the pups' odour. This may be the reason that many escapees returned to their home cage are then often attacked, killed and cannibalised by their parent or other adult members of the cage group.

4. Breeding

Female spiny mice have an 11 day oestrus cycle and unlike mice and rats, do not produce a vaginal plug following copulation (5). Time mated pregnancies are problematic in this species, however when males and females cohabit permanently a litter is born 40 days after the previous litter was born. It is now understood that female spiny mice exhibit a postpartum oestrus within 24 h of giving birth (2), and they can therefore carry foetuses of a subsequent pregnancy while still allowing pups from the previous litter to suckle.

4.1 Gestational length and number of pups/litter

The gestation length is 38-39 days with the mode being 39 days. Over 90% of all litters are born in the early hours of the morning. The number of pups per litter generally increases with subsequent litters. First pregnancies usually produce 1-2 pups, whereas subsequent litter size can be 1-5 pups with the average being 3 (Table 1). It is not known if this increase in litter size is due to a progressive increase in the number of ova released per cycle, or an increased capacity of the uterus to support a greater number of placentas and foetuses.

Table 1: Average litter size and maternal weight at term in successive litters

	Litter 1	Litter 2	Litter 3	Litter 4
Number of Pups per Litter	2.17±0.09 (n=51)	3.00±0.13# (n=47)	2.82±0.14# (n=34)	3.00±0.23# (n=11)
Maternal weight at term (g)	NA [*]	61.29±1.34 (n=6)	63.90±0.25 (n=3)	67.02±1.53* (n=4)

Values are means ± SE. n, No. of mice. * P<0.05 between litter 2 and 4, #P<0.001 for all litters compared to litter 1. ^{*}Due

to the nature of pregnancy determination in this species, the due date for females carrying their first litter is not known and so term weights are not easily obtained.

4.2 Determining gestational age

Determination of gestational age is easily achieved by a simple calculation from the date of birth of the previous litter. For example is litter one was born on day 025/07 (25th January 2007) then litter two would be due 40 days (39 days for gestation length plus 24h for postpartum oestrus and conception to occur) later on 065/07 (6th March 2007). If the gestational age required for treatment was day 20, then 21 days were added to the date of birth of the previous litter: 025/07 + 21 = 046/07. Day 20 of gestation of litter two is therefore 046/07 (15th February 2007).

4.3 Female weight gain and litter number

For collection of foetal tissues, pregnant females should always be weighed before harvesting. This is particularly important in the early to mid stages of gestation to ensure that the female is pregnant. The weight gain should be substantial; for example, a young adult female at 20 days gestation should weigh at least 41-44g. This weight is generally a minimum, as maternal weight at day 20 of gestation ranges from approximately 44-50g (Figure 1).

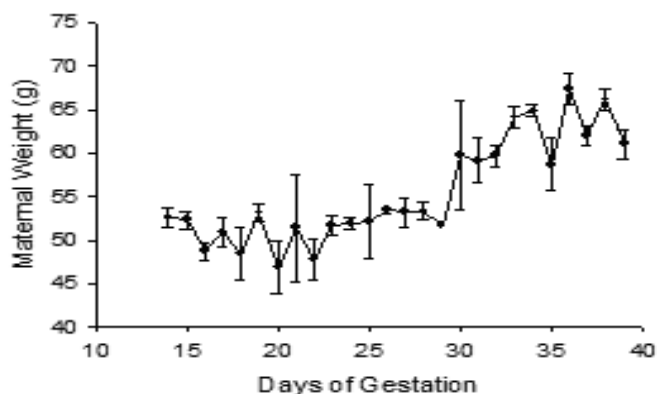

Figure 1. Maternal weights throughout gestation. These data represent the body weight of individual females humanely killed between gestational ages 14-39 (n=2/gestational age). All females were carrying at least their 2nd litter. Non-pregnant female spiny mice weigh between 35-40g.

Figure 1 shows that maternal weight increases considerably in late gestation. Term females can weigh over 65g, which is approximately a 50% increase in basal body weight. Figure 2 shows a late gestation female, with an obvious expansion of her abdominal region. As mentioned, females increase their average number of pups over subsequent litters and thus the size of their rump (Table 1). First litter females do not gain anywhere near the same amounts of weight as

second and subsequent litter females. Consequently, females that are due to deliver their first litter need to be checked daily (39-40 days after being cohabited), as their pregnancy is less obvious and the gestational age (and due date) are not known.



Figure 2. Comparison of pregnant and non-pregnant female spiny mice. Females can gain over 20g (~50% of their original body weight) during pregnancy.

We have recently performed serial ultrasound scans of pregnant female spiny mice. It is possible to detect foetuses from day 12 of gestation, and we are able to identify distinguishable foetal features, such as the proboscis, tail and hind brain from day 19 of gestation (Figure 3A). Definition of the fetal diaphragm, stomach, and liver are possible from day 21 of gestation and all foetal features are detectable from day 26 of gestation to term (Figure 3B-D). We have also been able to record foetal heart rate from day 15 of gestation and placental and uterine blood flows from day 26 of gestation.

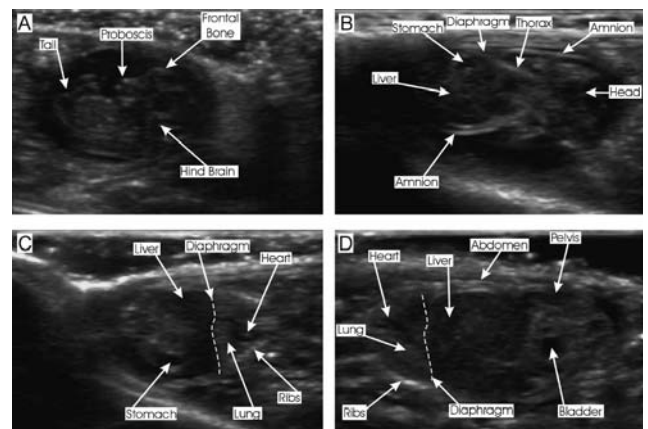

Figure 3: Ultrasound images of spiny mouse foetus at day 19 (A), 21 (B), 26 (C) and 28 (D) of gestation. Definition of the fetal diaphragm is possible from day 21 of gestation and all structures including liver, lungs, bladder, and stomach are detectable by day 26 of gestation.

4.4 Age of breeders

Female spiny mice are sexually mature at 7 weeks of age (5) and males are sexually mature at 8-9 weeks of age (23). Most successful breeding is achieved by waiting until the animals are 15-20 weeks of age before pairing them as breeders. Spiny mice can be fertile throughout their adult lifespan and will usually conceive and deliver litters every 40 days (personal observation).

4.5 Weaning

Spiny mice can be weaned from 2 weeks of age (5), but if left with the mother will go on feeding intermittently from her for several more weeks. If the mother has had a post-partum oestrus and is pregnant again, it is best to remove the pups from the previous litter at or before the birth of the next litter; i.e., before or by 40 days of age.

4.6 Sexing

At weaning age males tend to have fur between the anus and penis. As for other rodent species, females have a shorter ano-genital distance than males and have clearly visible mammae.

5. Common Health Problems

5.1 Tumours

Occasionally tumours occur in adult spiny mice. These present as large lumps and have been found in the leg, head, and jaw. It is not feasible to remove the tumours as they appear to be very aggressive, with a sudden appearance and marked growth, and it would be difficult to remove all the damaged tissue. They can be quite uncomfortable for the spiny mice, therefore it is appropriate to humanely euthanize these mice as soon as the tumours are noticed.

5.2 Injuries

Spiny mice often present with missing ears, tails or large chunks of fur, and scabbing at the site of the injury. These usually result from conflict with other spiny mice within the cage. There have been a number of instances where a male and female are setup for breeding, and the male is very aggressive toward the female. These females are often left with large areas of scabbing on their backs where the fur has been removed. These males are always humanely sacrificed and the female treated with antibiotic spray until the fur re-grows.

5.3 Diseases

No diseases have been encountered or identified in our colony of spiny mice. It has been reported that under poor hygiene conditions spiny mice may succumb to *Klossiella* sp. infection (24). This infection presented as interstitial nephritis but was cleared soon after hygiene standards improved.

6. Procedures and Protocols currently in use in spiny mice in our laboratory

There are a number of established protocols currently in use in our spiny mice colony. All these experimental protocols have been approved by Monash University School of Biomedical Sciences Animal Ethics Committees, and are conducted in accordance with the Australia Code of Practice for the care and use of animals for scientific purposes.

6.1 Anaesthesia and surgery

Anaesthesia (Isoflurane mixed with room air via inhalation, 4.5% induction and 2.5–2.8% maintenance dose; Rhodia Australia P/L, Notting Hill, VIC, Australia) is routinely used for spiny mice, with no obvious side effects. While anaesthetised, spiny mice maintain a relatively constant heart rate (400-450bpm) and blood pressure (60-65mmHg) for periods of at least 2.5 h, as measured via a carotid artery catheter connected to a pressure transducer and the signal sent to a personal computer for recording.

6.2 Experimental models

A model of 'birth asphyxia' has been developed - brief changes leading to moderate hypoxia and hypercapnia - mimicking the episodes that can be experienced by human babies at birth. The procedure involves maintaining term foetuses in the excised uterus at 37°C for 7.5 mins, then delivering and resuscitating them by clearing the mouth and airway, and gently palpating the chest with a moist cotton bud. The neonates are then used to assess both behavioural and brain development up to 30 days of postnatal age.

6.3 Substance administration

Using light anaesthesia, successful implantation of osmotic mini pumps has been achieved. The osmotic pumps allow constant, steady delivery of a wide range of substances directly into the animal. This eliminates the need to repeatedly inject animals and thereby reduces the stress for the animals.

We have used pregnant spiny mice to investigate the effects of glucocorticoid excess from mid-gestation. In these experiments, an osmotic mini pump filled with the synthetic glucocorticoid dexamethasone, is implanted (using brief isoflurane anaesthesia) under the skin on the spiny mouse's back, and the steroid is discharged subcutaneously for 60h from days 20-23 of gestation. This model has been used to examine the effects of maternal glucocorticoid excess on kidney development and on the basal blood pressure in the offspring as adults (25).

In addition to dexamethasone, treatment of pregnant animals with melatonin is under investigation.

6.4 Physiological recordings

Continuous, conscious blood pressure and heart rate are easily measured via a carotid artery catheter attached to a tether and liquid swivel system (25). This allows freedom of movement for the animal (Figure 4). The catheter is connected via the swivel to a pressure transducer relaying systolic and diastolic blood pressure readings to a personal computer for collection (26). Mean arterial pressure was calculated on a beat to beat basis and instantaneous heart rate was calculated from the pulse interval.

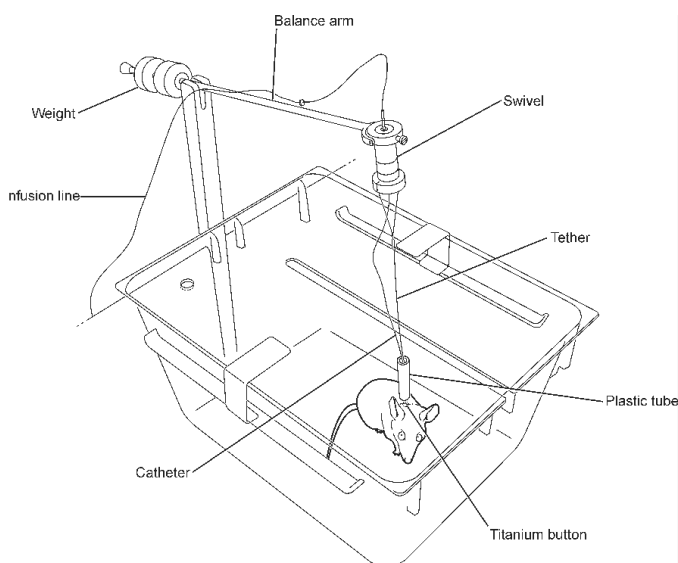

Figure 4: Spiny mouse on swivel system for continuous blood pressure measurement. Catheter is pulled through the titanium button stitched under the skin and attached to the tether and balance arm, allowing 360° unrestricted movement of the animal. Plastic tubing surrounds the base of the catheter to prevent the spiny mouse chewing the catheter. The swivel is attached to an infusion line which allows heparinised saline to flow into the catheter and the blood pressure to be detected by the pressure transducer and sent to a personal computer for recording.

Renal function can be measured in anaesthetised animals following insertion of carotid artery, jugular vein and bladder catheters (Figure 5). Glomerular filtration rate and renal blood flow have been measured by the clearance of radioactive inulin (^3H -Inulin) and para-aminohippurate (^{14}C -PAH) respectively.

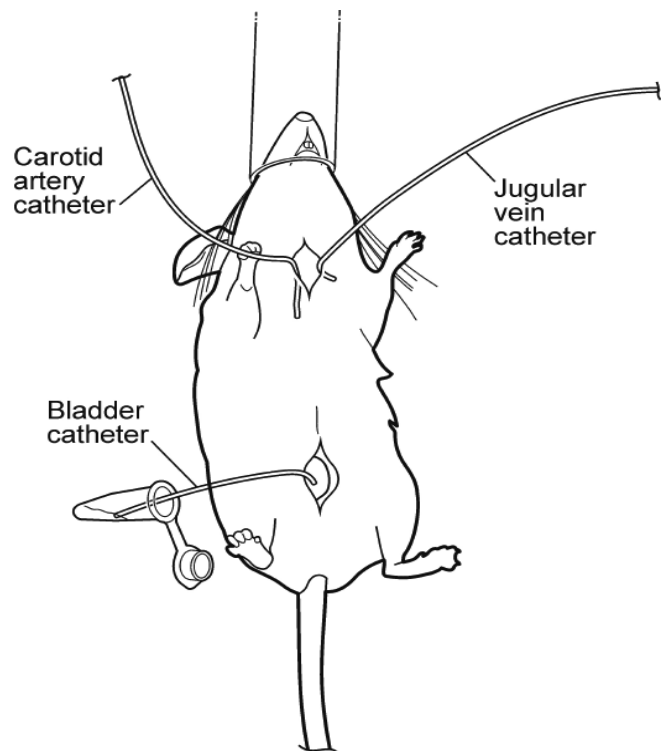

Figure 5: Catheter implantation sites for renal function experiments. While anaesthetised, the right carotid artery, left jugular vein and bladder of spiny mice are each catheterised to monitor blood pressure, allow continuous fluid infusion and urine collection respectively.

6.5 Metabolic studies

Metabolic cages are routinely used to accurately measure food and water consumption and faeces and urine production. This is particularly useful when dietary manipulations are involved to provide a general description of the metabolic status of the animal. It is very important to habituate spiny mice within the metabolic cages for at least 1 x 8h and 1 x 24h period before the experimental 24h collection period, since the mouse is separated from other mice and the metabolic apparatus is a smaller space than the home cage. Significant weight loss (>1g) or large amounts of food shredding are indicators of stress. If these occur during experimental collection periods the mouse should be given 2-3 days to rest and the experiment repeated.

6.6 Neonatal and adult behavioural tests

We have adapted 3 behavioural tests for use with newborn spiny mice - the open field test, rotarod

test, and footprint task. These tests are useful for investigating development of behaviour and motor abilities in the early postnatal period, and can also be utilised to assess neurological deficits following an *in utero* or perinatal insult. The tests evaluate spontaneous locomotion (27), motor coordination (28), balance and walking pattern or gait (29), and are based on tests routinely used for juvenile and adult rodents. An advantage of the spiny mouse is that this kind of testing can start from the 1st postnatal day of life.

7. Prospective research

As briefly described spiny mice are an ideal model for foetal and perinatal research. The spiny mouse shows an advanced stage of brain development at birth compared to altricial rodents, while still undergoing substantial postnatal development as in the human. They show more advanced development of white matter tracts than the term rat or mouse (30) and therefore they may be a more appropriate model for studying the effects of hypoxic and infectious stimuli on the developing brain than the conventional newborn rodent. We are particularly interested in understanding the impact of mild hypoxic/hypercapnic changes that can occur around the time of birth, and of transient hypoxic episodes during late gestation, since these are events that challenge the human foetus at a similar stage of brain development. We have shown that a brief (7.5 min) hypoxia/hypercapnia episode at day 37 of gestation reduces neonatal survival and leads to behavioural deficits that persist for at least 2 weeks. We are currently characterising the brain damage associated with these behavioural deficits. We will examine the impact of both maternal creatine and melatonin administration on neonatal survival and brain damage after hypoxic/hypercapnic insults at birth or during late gestation.

We have shown that nephrogenesis is complete before birth in this species, which distinguishes them from known rodent species (2). Opportunities therefore exist to examine the impact of alterations in the intrauterine environment on kidney development, which represents a significant refinement over existing rat and mouse models where the comparable stages of development occur after birth. It will be interesting to examine the development of other major organ systems, especially the lungs and heart, as these organs are also often compromised in human pregnancies characterised by chronic hypoxia, prematurity, foetal growth retardation damage, or maternal stress. Of particular clinical relevance is the production of surfactant in the developing lung and the impact of pre-term labour

and glucocorticoid treatment on subsequent lung development.

Indeed, the spiny mouse may be an excellent model to examine the effects of pre-term birth as the more advanced stage of foetal development in this species increases the likelihood of neonates surviving pre-term birth. This would provide an opportunity to examine the short and long-term effects of pre-term birth in a small animal model.

In collaboration with Dr Claire Roberts (University of Adelaide) we are also describing the ontogeny of the placenta of the spiny mouse, particularly in relation to the development of the labyrinth and junctional zones as well as the expression of insulin-like growth factor-2 and 11 β hydroxysteroid dehydrogenase-2 activity throughout gestation. Like the human and mouse (*Mus musculus*) placenta, the spiny mouse placenta is discoid. We have described the foetal-maternal exchange barrier in late gestation (day 37) placentas and found it to be haemotrichorial (3 layers of trophoblast between the foetal and maternal circulations) as in the mouse.

We are also investigating the development of the immune system in the spiny mouse, to establish whether immunocompetence is acquired prior to birth as in the human, or after birth as in altricial rodent species.

As mentioned above, because of its advanced development at birth, the spiny mouse is well suited as a model for studying the effects of an adverse intrauterine environment on foetal development and the effects of potential therapies. Maternal diet can be easily manipulated to study the effects of maternal malnutrition, stress, diabetes, hypertension, and obesity. In addition, the spiny mouse is ideal for the study of foetal exposure to drugs, alcohol and smoking as well as placental insufficiency and restricted uterine blood flow. These are all commonly associated with increased neonatal morbidity and mortality in human infants.

Our utilization of ultrasound technology to view the foetus *in utero* offers the opportunity to reduce the number of animals used, as serial scans can be made in a single pregnant female without the need to sacrifice individual animals at specific times in gestation. Possible measurements using ultrasound include foetal and placental growth, foetal heart rate, breathing movements, micturition, and foetal behaviour, all of which provide insight into the physical and functional development of the spiny mouse foetus.

8. Summary

Spiny mice are a different and relatively under-utilized species in which to conduct research, particularly perinatal research. They are active and curious species that seem to be well aware of their environment and the presence of new or unfamiliar people. The spiny mouse is proving to be a promising model for foetal and neonatal research. We believe that it offers many advantages over traditionally used rodent models and that it can replace the use of large non-primate animals such as the sheep for many studies related to pregnancy and foetal/neonatal development. used rodent models and that it can replace the use of large non-primate animals such as the sheep for many studies related to pregnancy and foetal/neonatal development.

9. Acknowledgements

Many thanks to Debbie Lane and her staff for maintenance of the spiny mouse colony, and to Zoe Ireland, Bobbi Slattery and Lisa Hutton for their assistance with the breeding program. We thank Michelle Kett, Karen Moritz, E. Marelyn Wintour, Claire Roberts and Tania Griffiths for assistance with experimental design and technique and Jake Pomeranz for producing all diagrammatic figures in this manuscript.

10. References

1. Walker E. Mammals of the world. 2nd ed: The John Hopkins Press; 1968.
2. Dickinson H, Walker DW, Cullen-McEwen L, Wintour EM, Moritz K. The spiny mouse (*Acomys cahirinus*) completes nephrogenesis before birth. *Am J Physiol Renal Physiol*. 2005 Aug;289(2): F273-9.
3. Fluckiger E, Operschall P. Die Funktionelle Reife der Neurohypophyse bei neonaten Nestfluchtern und Nesthockern. *Rev Suisse Zool*. 1962;69:297-301.
4. D'Udine B, Gerosa E, Drewett RF. Maternal behavior and the milk ejection reflex in a precocial murid (*Acomys cahirinus*). *Behav Neural Biol*. 1980 Mar;28(3):378-81.
5. Peitz B. The oestrous cycle of the spiny mouse (*Acomys cahirinus*). *J Reprod Fertil*. 1981;61:453-9.
6. Creutzfeldt W, Mende D, Willms B, Soling H. Vascular basement membrane thickness in muscle of spiny mice and activities of glycolysis and gluconeogenesis in the liver of animals with spontaneous and experimental diabetes and of untreated human diabetes. *Diabetologia*. 1970;6:356-60.
7. Gonet A, Stauffacher W, Pictet R, Renold A, Mougou J. Obesity and Diabetes Mellitus with Striking Congenital Hyperplasia of the Islets of Langerhans in Spiny Mice (*Acomys Cahirinus*). *Diabetologia*. 1965;1:162-71.
8. Gutzeit A, Rabinovitch A, Struder PP, Trueheart PA, Cerasi E, Renold AE. Decreased intravenous glucose tolerance and low plasma insulin response in spiny mice. (*Acomys cahirinus*). *Diabetologia*. 1974 Nov;10 Suppl:667-70.
9. Gutzeit A, Renold A, Cerasi E, Shafir E. Effect of Diet-induced Obesity on Glucose and Insulin Tolerance of a Rodent with a Low Insulin Response (*Acomys cahirinus*). *Diabetes*. 1979;28:777-84.
10. Hunt C, Lindsey J, Walkley S. Animal models of diabetes and obesity, including the PBB/Ld mouse. *Fed Proc*. 1976;35(5):1206-17.
11. Shafir E. Overnutrition in spiny mice (*Acomys cahirinus*): Beta-cell expansion leading to rupture and overt diabetes on fat-rich diet and protective energy-wasting elevation in thyroid hormone on sucrose-rich diet. *Diabetes Metab Res Rev*. 2000;16:94-105.
12. Strasser H. A breeding program for spontaneously diabetic experimental animals: *Psammomys Obesus* (Sand Rat) and *Acomys cahirinus* (Spiny Mouse). *Lab Anim Care*. 1968;18(3):328-38.
13. Porter RH, Doane HM. Maternal pheromone in the spiny mouse (*Acomys cahirinus*). *Physiol Behav*. 1976 Jan;16(1):75-8.
14. Porter RH, Tepper VJ, White DM. Experiential influences on the development of huddling preferences and "sibling" recognition in spiny mice. *Dev Psychobiol*. 1981 Jul;14(4):375-82.
15. Brunjes PC. A comparative study of prenatal development in the olfactory bulb, neocortex and hippocampal region of the precocial mouse *Acomys cahirinus* and rat. *Brain Res Dev Brain Res*. 1989 Sep 1;49(1):7-25.
16. Brunjes PC. Olfactory bulb maturation in *Acomys cahirinus*: is neural growth similar in precocial and altricial murids? *Brain Res*. 1983 Jun;284(2-3):335-41.
17. Birke LI, D'Udine B, Albonetti ME. Exploratory behavior of two species of murid rodents, *Acomys cahirinus* and *Mus musculus*: A comparative study. *Behav Neural Biol*. 1985 Mar;43(2):143-61.
18. Dieterlen F. Vergleichende Untersuchungen zur Ontogenese von Stachelmaus (*Acomys*) und Wanderratte (*Rattus norvegicus*) Beitrage zum Nesthocker-Nestfluchter-Problem bei Nagetieren. *Zeitschrift fur Saugetierkunde*. 1962;28:193-227.
19. Lamers WH, Mooren PG, Griep H, Endert E, Degenhart HJ, Charles R. Hormones in perinatal rat and spiny mouse: relation to altricial and precocial timing of birth. *Am J Physiol*. 1986 Jul;251(1 Pt 1): E78-85.
20. Oosterhuis WP, Mooren PG, Charles R, Lamers WH. Perinatal development of the lung in rat and spiny mouse: its relation to altricial and precocial timing of birth. *Biol Neonate*. 1984;45(5): 236-43.
21. Brunjes PC. A stereological study of neocortical maturation in the precocial mouse, *Acomys cahirinus*. *Brain Res*. 1985 Apr;351(2): 279-87.

22. Kam M, Degen A. Effect of dietary preformed water on energy and water budgets of two sympatric desert rodents, *Acomys russatus* and *Acomys cahirinus*. *Journal of zoology: Proceedings of the zoological society of London*. 1993;231:51-9.
23. Peitz B, Foreman D, Schmitt M. The reproductive tract of the male spiny mouse (*Acomys cahirinus*) and coagulation studies with other species. *J Reprod Fertil*. 1979;57:183-8.
24. Meshorer A. Interstitial nephritis in the spiny mouse (*Acomys cahirinus*) associated with *Klossiella* sp. infection. *Lab Anim*. 1970 Oct;4(2):227-32
25. Dickinson H, Walker DW, Wintour EM, Moritz K. Maternal dexamethasone treatment at midgestation reduces nephron number and alters renal gene expression in the fetal spiny mouse. *Am J Physiol Regul Integr Comp Physiol*. 2007 Jan;292(1):R453-61.
26. Navakatikyan MA, Barrett CJ, Head GA, Ricketts JH, Malpas SC. A real-time algorithm for the quantification of blood pressure waveforms. *IEEE Trans Biomed Eng*. 2002 Jul;49(7):662-70.
27. Noldus LP, Spink AJ, Tegelenbosch RA. EthoVision: a versatile video tracking system for automation of behavioral experiments. *Behav Res Methods Instrum Comput*. 2001 Aug;33(3):398-414.
28. Jones BJ, Roberts DJ. A rotarod suitable for quantitative measurements of motor incoordination in naive mice. *Naunyn Schmiedebergs Arch Exp Pathol Pharmacol*. 1968;259(2):211.
29. Klapdor K, Dulfer BG, Hammann A, Van der Staay FJ. A low-cost method to analyse footprint patterns. *J Neurosci Methods*. 1997 Jul 18;75(1):49-54.
30. Craig A, Ling Luo N, Beardsley DJ, Wingate-Pearse N, Walker DW, Hohimer AR, et al. Quantitative analysis of perinatal rodent oligodendrocyte lineage progression and its correlation with human. *Exp Neurol*. 2003 Jun;181(2):231-40.

Contact Information:

Hayley Dickinson
 Monash Immunology & Stem Cell Laboratories
 School of Biomedical Sciences,
 Monash University,
 Clayton, 3800,
 Victoria, Australia

Tel: 61-3-9902 0286
 Fax: 61-3-9905 0680
 Email: Hayley.Dickinson@med.monash.edu.au

6th World Congress on Alternatives & Animal Use in the Life Sciences

This year's World Congress is being held from the 21st to 25th August in Tokyo, Japan. For further information visit the website at www.ech.co.jp/wc6/

ANZCCART NEWS ©

**is free of charge and is published by the
 Australian and New Zealand Council for the Care of
 Animals in Research and Teaching Limited.**

**It is a publication for researchers and teachers; members
 of Animal Ethics Committees; staff of organisations
 concerned with research, teaching and funding; and
 parliamentarians and members of the public with
 interests in the conduct of animal-based research and
 teaching and the welfare of animals used.**

**The opinions expressed in ANZCCART NEWS are not
 necessarily those held by ANZCCART Ltd.**

**Contributions to ANZCCART NEWS are welcome and
 should be sent to:**

ANZCCART

**C/- The University of Adelaide
 South Australia 5005
 Australia**

Tel. 61-8-8303 7585 Fax. 61-8-8303 7587

E-mail. anzccart@adelaide.edu.au

<http://www.adelaide.edu.au/ANZCCART>

or

**ANZCCART New Zealand
 PO Box 598
 Wellington
 New Zealand**

Tel. 64-4-472 7421 Fax. 64-4-473 1841

**E-mail. anzccart@rsnz.org
<http://anzccart.rsnz.org/>**

ISSN 1039-9089