

---

## **A bushfire monitoring and detection system for smart homes using ZigBee technology**

---

Ying Sun, Quan Yuan and Said Al-Sarawi\*

Centre for High Performance Integrated Technologies – CHiPTec,  
School of Electrical and Electronic Engineering,  
Faculty of Engineering, Computer and Mathematical Sciences,  
The University of Adelaide,  
Adelaide, SA 5005, Australia  
E-mail: yingsun@eleceng.adelaide.edu.au  
E-mail: quan.yuan@alumni.adelaide.edu.au  
E-mail: alsarawi@eleceng.adelaide.edu.au  
\*Corresponding author

**Abstract:** This paper describes the part of a smart monitoring system that uses ZigBee modules to communicate sensory information in case of a fire or bushfire. The proposed system is composed of two parts: A number of remote boards that collect temperature and humidity; and a host board that contains the same type of sensors as the remote board, in addition to wind speed and wind directions sensors. The proposed system can be used for monitoring and detection of both bushfire and fire in and around a house. The host board position and sensory information collected from the remote boards are combined, stored and processed by a microcontroller. The host board performs further processing on the collected sensory information and communicates it to a control room wirelessly using a long range wireless communication such as wireless local area network (WLAN) or general packet radio service (GPRS). The system components and performance are also described.

**Keywords:** bushfire; ZigBee; microcontroller; distributed sensors; global positioning system; GPS.

**Reference** to this paper should be made as follows: Sun, Y., Yuan, Q. and Al-Sarawi, S. (2010) 'A bushfire monitoring and detection system for smart homes using ZigBee technology', *Int. J. Computer Aided Engineering and Technology*, Vol. 2, Nos. 2/3, pp.234–249.

**Biographical notes:** Ying Sun received her Bachelor degree from Xi'an Jiaotong University, Xi'an, ShaanXi, China, in 2005. She finished her Master of Engineering (Advanced) in Sensor Systems Signal Processing from the University of Adelaide, in 2007. Currently she is a PhD candidate in the University of Adelaide. Her research interests are insect vision systems and distributed sensors network.

Quan Yuan received his Bachelor degree from the Beijing University of Aeronautics and Astronautics, Beijing, China, in 2005. He finished his Master of Engineering (Advanced) in Telecommunications, from the University of Adelaide, in 2007. His research interest is in distributed wireless network.

Said Al-Sarawi is a Senior Lecturer in the School of Electrical and Electronic Engineering, The University of Adelaide, Adelaide, South Australia. He

received his BEng in Marine Electronics and Communication from AAST, Alexandria, Egypt, in 1990 and finished his PhD with special commendations in Low Power, Low Voltage Design Techniques for Smart Wireless Systems from The University of Adelaide, in 2003. His research interests include design techniques for mixed signal systems in CMOS and optoelectronic technologies for high performance radio transceivers, high speed data converters and mixed signal design for biomedical applications and distributed wireless networks.

---

## **1 Introduction**

Bushfires are one of the most dreaded of natural phenomena on earth and account for the majority of deaths and injuries when compared with other natural disasters combined, such as floods, hurricanes, tornadoes, earthquakes, etc. (US Fire Administration and National Fire Data Center, 2007). Sometime these fires have certain positive impacts (Ganewatta and Handmer, 2006), however, their negative impacts are more severe when considering the hundreds of lost lives, thousands of dead animals, and properties damaged.

Bushfires are major issues in many places around the world. As Kaval (2009) indicated, billions of dollars are spent on wildfire attack each year in the USA. According to Westerling et al. (2006), increased number of bushfires occurred in western forests in recent years, including those of the Sierra Nevada, Southern Cascade, and Coast Ranges of Northern California. Gomes (2006) reported that more than 200,000 hectares were burned in forest fires that took place in Portugal during July and August 2005, during the country's worst drought in decades. In South-East Asia, Indonesian environmental authorities were on full alert as bushfires occur every year (Jhamtani, 1998) and result in negative impacts on economic, ecological and social environments, including the loss of timber and non-timber forest crops, the loss of biodiversity, increased wildlife mortality, and contribution to global warming.

In recent years, bushfires have caused tremendous economical and life losses in Australia due to its natural habitat (Commonwealth of Australia, 2001). During the summer of 2003, up to almost four million hectares in the Australian Capital Territory and across five Australian states were severely damaged from wildfire (Australia Parliament, House of Representatives Select Committee on the Recent Australian Bushfires, 2003). During the period between 2000 and 2009, three devastating bushfires have occurred in Australia. On February 2009, as reported by Roberts and McMahan (2009), the terrible Victorian bushfires claimed the lives of 173 people and resulted in more than 500 injuries.

Bushfires will continue to threaten the world's ecosystem, environment, and economical development. The ability to predict and prevent bushfires especially next to inhabited areas and around properties is becoming more urgent and critical.

In this paper, we propose a cost-efficient and high-performance bushfire monitoring and detection system to be used in and around a house. The remote boards can also be mounted in each room or passage in the house to allow for continuous monitoring and detection in case of fire. The integration of such system with current houses will result in smart houses as it allows continuous monitoring and early detection of fires in and around a house.

The proposed system architecture is given in Section 2, followed by a description of the hardware modules in Section 3. The system software is presented and discussed in Section 4. The system performance and evaluation are presented in Section 5. This is then followed by a conclusion.

## 2 System architecture

The proposed system is composed of two parts. The first part comprises of a number of remote boards (slaves) that collect sensory information, while the second is a host board (master) that collects similar information as the remote board in addition to wind speed and direction sensors as shown in Figure 1.

**Figure 1** Application of the proposed system in a smart home environment (see online version for colours)

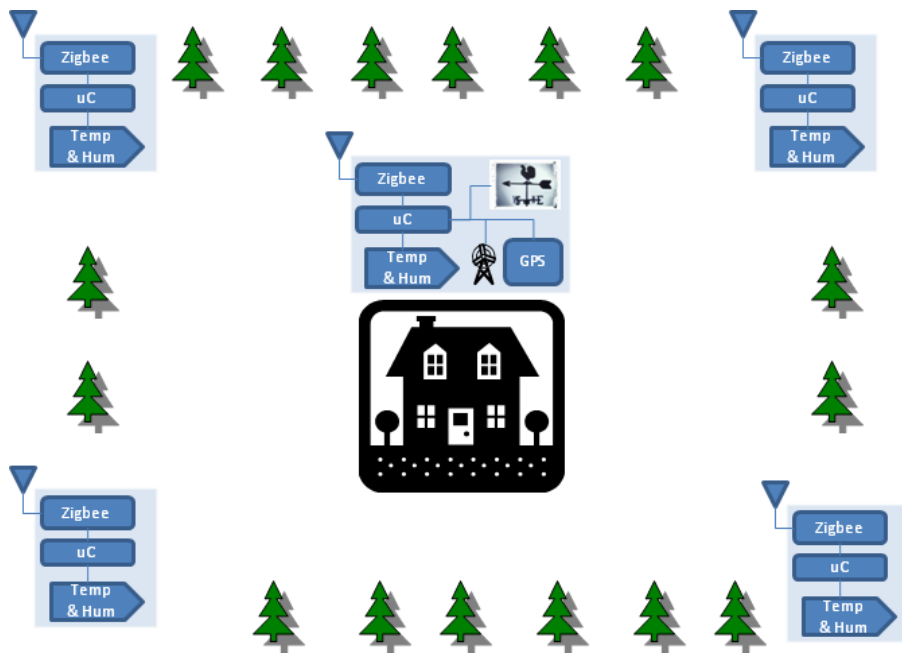

In the following sections, the host board with the four integrated sensors is described. The microcontroller (uC) in the host board collects humidity, temperature, wind speed and wind direction sensory information, then processes all the collected information and triggers an alarm when some measurements exceed predefined thresholds. A global positioning system (GPS) receiver module was used to report the boards' location. The host board, through a long range communication interface, accomplishes wireless communication with a control room. The communication range of the used ZigBee modules can be up to 90 metres in an outdoor environment, depending on the transmission power level (MaxStream Inc., 2007). For each of these host boards, a solar cell panel was also used to harvest solar energy and store it in a high capacity battery,

which was employed to provide the needed power to operate them at all time. An overview of the whole system is shown in Figure 2. As can be seen from the figure, the host board has more sensors than the remote board, this is intended to reduce their cost and reduce the amount of power consumed by them. When these remote boards are integrated into a home, there is no need to have a solar cell system, instead a rechargeable battery that is connected to the home electrical network would be more appropriate. Furthermore, to detect fire inside a house there might be a need to have a smoke detector added to the remote board, this is shown in dashed line in Figure 2(b).

**Figure 2** The overall monitoring and detection system block diagram, (a) shows the block diagram of the host board block diagram (b) shows the remote board block diagram

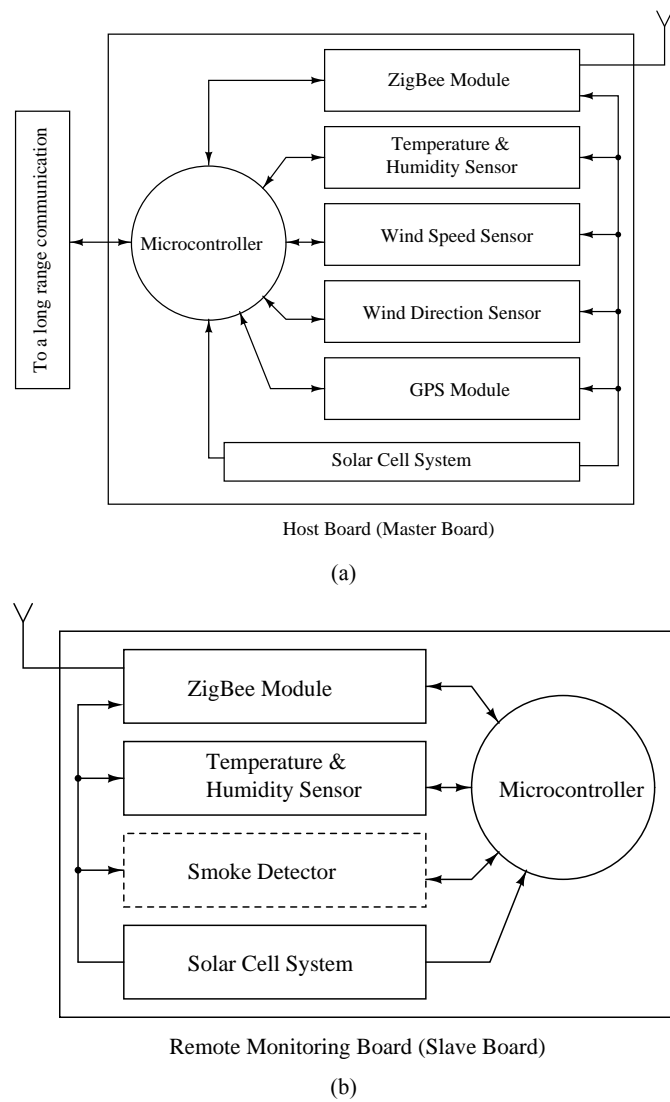

### 3 System hardware modules

Considering the environment where the monitoring system will be placed in, there are several requirements for each element in this system. Firstly, all the sensors should be sensitive and precise to detect sensory information that is an indication of potential fire or bushfire. Secondly, all the devices should operate reliably and have good performance. Thirdly, the power consumption of all the components should be as small as possible. Fourthly, it should be fire resistant and maintains as long life as possible in case of a fire or bushfire. These criteria are addressed as follows: the sensitivity and preciseness of the sensors were achieved by selecting sensors that have the following requirements: the relative humidity, temperature, wind speed and wind direction resolutions should be better than 0.1%, 0.1°Celsius, 0–100 km/h, and 25°, respectively. The reliability of operation is considered through the design of the modules and allowing the microcontroller enough time for the measurements of the different sensory information before processing collected sensory information while taking into account the possible variation in operation frequency due to heat. The power consumption reduction is addressed through the selection of low power components and shutting down modules between measurements. For the fire resistant part, the module can be packaged in an aluminium housing box. However, this will not fully protect the module as a number of these sensors have to be exposed to the external environment to accurately measure the temperature and humidity information. On the other hand, it is not possible to ensure that these boards will survive a fire, rather allow them as long time as possible to keep sending sensory information before they are damaged. In the following subsection, the different modules that compose the host board are described. The remote board will not be discussed as it is a cut down version of the host board.

#### 3.1 *Microcontroller module*

In order to observe the environmental conditions in and around a house, the microcontroller needs to collect the boards' position and analyse the received information from all the remote board sensors. As the microcontroller module will be active all the time, it is important that this device consumes as low power as possible, so an ultra low power MSP430F1611 microcontroller from Texas Instruments Incorporated (2006) was chosen. The low power operation of this controller is achieved by switching among six operating modes for different requests to save energy. This controller is 16-bit RISC CPU architecture that has six input/output ports, two universal synchronous asynchronous receiver transmitter (USART) ports and one successive approximation analog-to-digital converter (ADC). In addition, this microcontroller has a small footprint ( $9 \times 9 \text{ mm}^2$ ).

#### 3.2 *Temperature and humidity sensors*

The combined temperature and humidity sensors (SHT75), manufactured by The Sensirion Company (2004), were used because they can measure humidity from 0% to 100% and temperature from  $-40^\circ$  Celsius to  $123^\circ$  Celsius. The resolution of humidity and temperature measurement are 0.03% and  $0.01^\circ$  Celsius, respectively.

The communication between the microcontroller and the SHT75 uses a serial interface over two bidirectional wires, in addition to supply voltage terminals. One serial

clock input (SCK) pin was used to synchronise the communication between the microcontroller and the sensor. The interface circuit is shown in Figure 3.

To meet the requirement of high speed and low power consumption, the measurement resolutions of temperature and humidity were set to 12-bit and 8-bit, respectively. The relative humidity measured by this sensor is strongly dependent on its temperature, so it was essential to keep the relative humidity sensor exposed to the same environment as the temperature sensor to simultaneously measure both the relative humidity and the temperature with no errors. Therefore, the SHT75 was placed out of the metal box and connected to the printed circuit board through ribbon wires.

**Figure 3** Interface between SHT75 and microcontroller

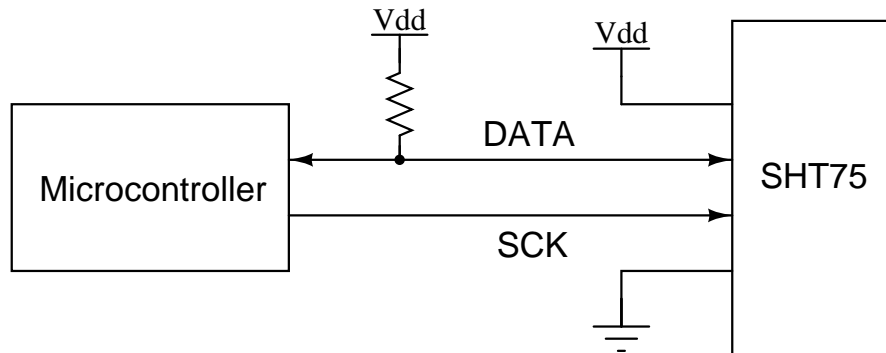

### 3.3 Wind direction sensor

Common wind-direction measurement device only provide three bits of information, which might be enough in some applications. For the proposed device, a more accurate way to measure wind-direction was devised, which utilises a continuous potentiometer. So, the wind direction is converted to resistance, which corresponds to a voltage drop across it, as shown in Figure 4. To reduce the power consumption, an n-type MOS transistor was used to connect one terminal of the potentiometer to ground. When this transistor is off, the voltage drop across the potentiometer is zero, hence the ADC from the microcontroller reads the supply voltage value indicating the true north direction. On the other hand, when the transistor is on, a voltage drop across the potentiometer will develop. The measured voltage drop by the ADC depends on the potentiometers shaft position. The shaft is connected to a vertical plat that is deflected by the wind direction. Therefore, there is a need to set a reference direction when installing the device before being able to get any valid measurements. In our case, we have used the earth north pole direction as our reference direction. Using this approach, it is possible to measure directions up to 360° counter clockwise relative to the reference direction.

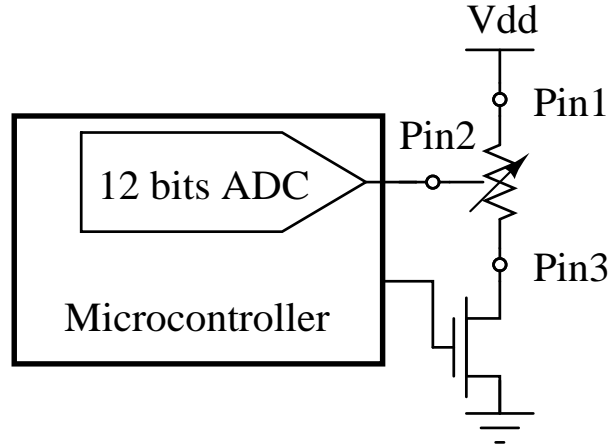
**Figure 4** Wind direction sensor

### 3.4 Wind speed sensor

A reed magnetic switch was used to measure the wind speed from 0 to 100 km/h as specified in Campbell Scientific Inc. (2001). When the reed slice turns half a round, the magnetic switch turns on. After the reed slice turns another half round, the magnetic switch turns off. The wind speed is measured by counting the number of rounds the reed slice turns, which produces a pulse wave. The microcontroller records the number of pulses within an eight second interval and converts them to speed in m/h. After eight seconds, the timer is shut down to reduce the power consumption of this sensor.

### 3.5 GPS module

A GPS module from Fastrax Ltd. (2004) (uPatch02) was used. This module is interfaced with the microcontroller using USART port and the communication speed was set to 4800 bps baud rate. The GPS fix data (GPGGA) NMEA message was collected (Fastrax Ltd., 2004). According to the National Marine Electronics Association Standard (1994), the format of the message can be interpreted as follows:

$$\text{GPGGA, hhmmss.dd, xxmm.dddd, <N|S>, yyym.dddd, <E|W>, v, ss, d.d, h.h, M, g.g M, a.a, xxxx* hh <CR> <LF>}$$

where hhmmss.dd, xxmm.dddd, <N|S>, yyym.dddd, <E|W> correspond to coordinated universal time (UTC), latitude, north or south, longitude, and east or west direction, respectively. These are the informations that were collected in the module, explanation of the rest of these arguments is given in National Marine Electronics Association Standard (1994).

### 3.6 *ZigBee RF module*

The XBee OEM RF module was selected because of its low cost and small size. According to the datasheet, this module can send and receive signals in wide range areas up to 90 metres with 250 kbps data rate in an open area, as specified in MaxStream Inc. (2007). Power consumption of this module has been reduced by putting the XBee module into sleep mode when there is no data transmission.

### 3.7 *Solar cell module*

A solar cell panel was used to provide the needed power to the host board, to make it independent from the house electrical power network. The panel provides a minimum of 12 Volt and 10 Ampere current at most and has its own rectifier and charger (Shell Solar, 2007). The panel's solid-state controller requires 3.2 mA to operate. The collected power was used to charge a high capacity 12 Volt battery. Considering the amount of power consumed by the proposed device, the collected power will allow the operation of the host and remote boards for a number of days without the need to recharge.

## **4 System software**

In addition to hardware, another important part for system design is the software, which was developed using IAR embedded workbench that allows the development of software using C programming language. The flowchart of the main program is shown in Figure 5, which describes the operation of the whole system. When powering the host board, all modules are initialised and the ZigBee module is set to sleep mode till all the sensory information are collected by the microcontroller. The operation of the board starts by collecting humidity and temperature information. Then, the wind speed is measured over an eight seconds period as described before. This is then followed by wind direction measurements using the integrated ADC in the microcontroller. After that, the GPS module is activated, wake up, to acquire the boards' position. This information is combined with the collected information from the remote boards and tested against predefined temperature and humidity thresholds. If the measured information is more than the predefined temperature and less than a predefined humidity, an alarm is set and the information will be sent to a control room at very small intervals of time, otherwise the collected information are sent to a control room at much longer periods of time. The sensors are turned-off after each data acquisition to reduce the overall power consumption of both the host and remote boards. The software operation of the remote board is similar to the host board with the wind speed, wind direction, while the GPS information acquisition is removed from flowchart.

**Figure 5** The main flowchart of the remote board

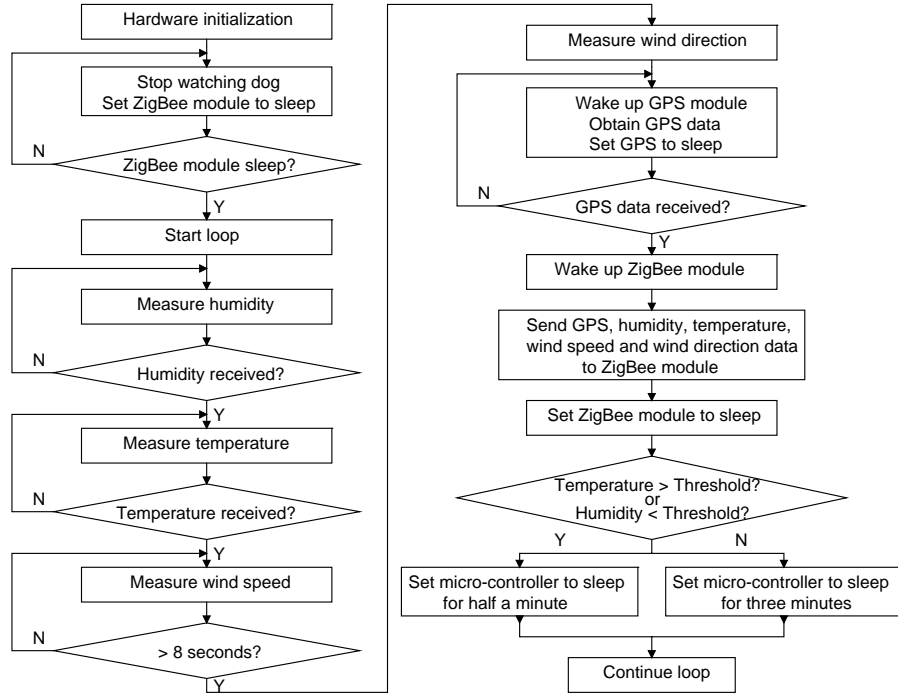

## 5 System performance

In the following subsection, the final boards performance is presented.

### 5.1 Host and remote boards

Two printed circuit boards have been designed, manufactured and tested. The fabricated host and remote PCB boards are shown in Figures 6(a) and 6(b), respectively. The whole bushfire monitoring system is shown in Figure 7. The solar panel, wind-speed and wind-direction modules dominate the size of the device, while the electronic part is very small in comparison.

To mimic the control room operation, where an operator would observe collected sensory information and act upon, a graphical user interface (GUI) using Matlab was developed. A sample test result is shown in Figure 8. From the GUI, it can be seen that the test was taken at approximately 15:24 pm UTC time. The reported location of the host board was south 34° 54.9947 minute and east 138° 36.2265 minute, which accurately indicates the laboratory position where these measurements were conducted in the University of Adelaide. The wind speed was 0.13 m/h and wind direction was 187.29° counter clockwise relative to the North Pole. The threshold of relative humidity and temperature were set to 40% and 40°Celsius, respectively. As shown in Figure 8, if any

of these factors exceed a predefined threshold a visual alarm is set by displaying the measured sensory information in red. Under this pre-alarm circumstance, information is updated every 30 seconds instead of three minutes in normal state. In addition, there is an option where the operator can activate the alarm system based on his/her observation by pressing the rescind alarm button.

**Figure 6** A photograph of the (a) the host and (b) remote boards of the bushfire detection and monitoring system (see online version for colours)

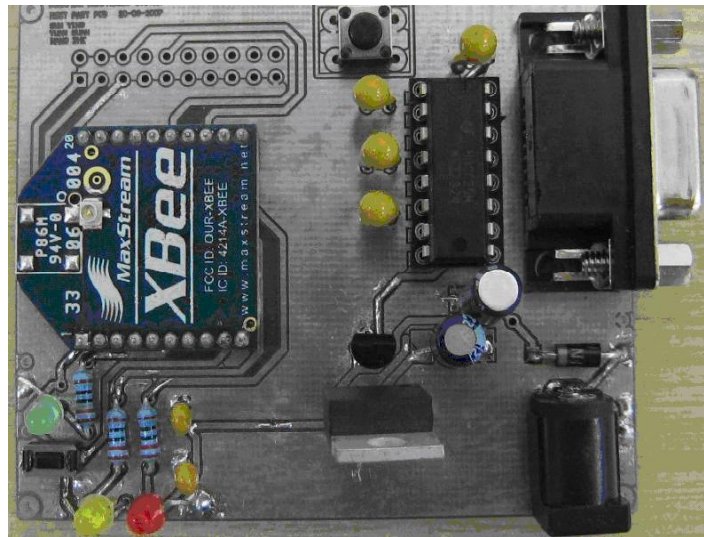

(a)

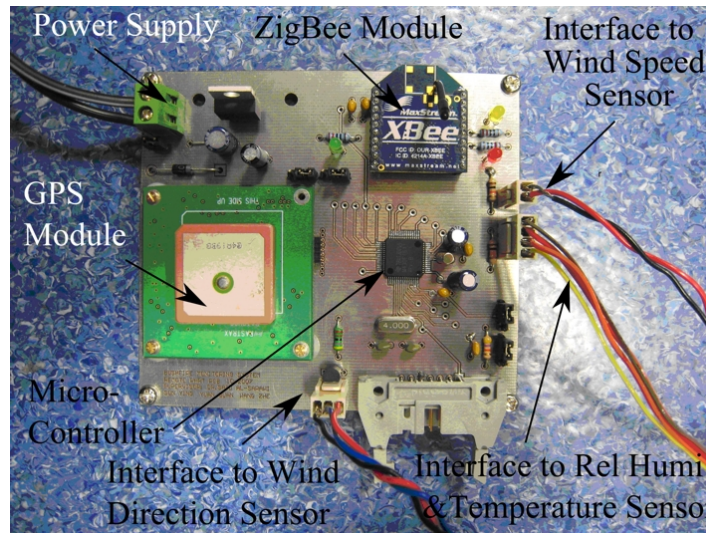

(b)

Note: Also shows RS232 interfaces used to interface with a computer.

**Figure 7** The whole bushfire monitoring and detection system (see online version for colours)

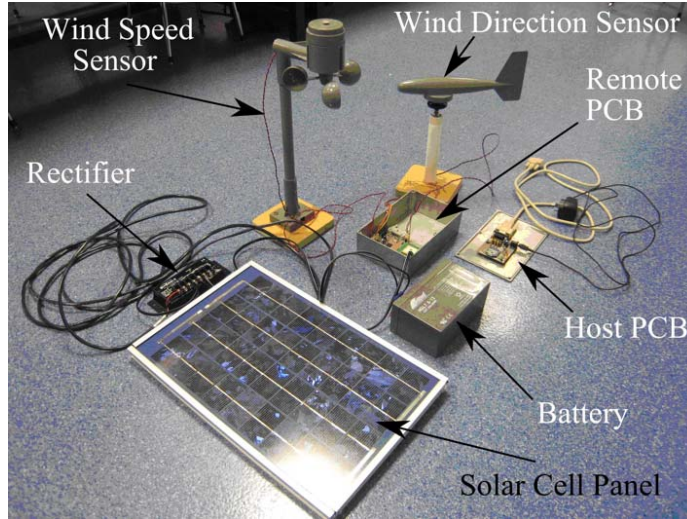

Note: This photo shows all the different modules of the system.

**Figure 8** A GUI to help an observer to monitor a bush environment or detect a fire (see online version for colours)

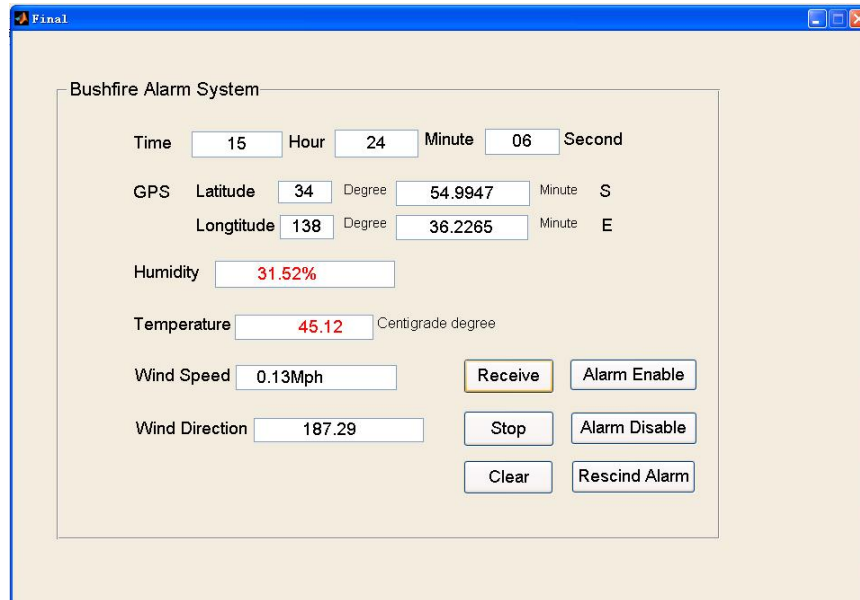

Note: Also allow the observer to send a rescind message to set the alarm.

## 5.2 System evaluation

The functionality of the system was evaluated through running the host board for a week by setting the host board in a location and logging the collected information at 9:30 am, 12:30 pm and 3:00 pm each day as shown in Table 1. This information was collected using a PC that is connected to the host board using a serial interface. As can be seen from the table, there are slight variations in the acquired location of the host board, these variations are caused by intentionally moving the host board to a number of locations to ensure correct operation of the GPS module during the testing.

The proposed bushfire monitoring system has a number of advantages, summarised as follows:

- **Low power consumption:** In this system, XBee and GPS modules are the two major power consuming components. These modules are put into sleep mode when they are not used. Furthermore, the wind direction sensor is controlled by the microcontroller via an n-type MOS transistor to reduce power. The overall power consumption is listed in Table 2.
- **Low cost:** The cost for building the system is around AU\$697. The major cost component is the GPS module. The cost can be reduced by using a unique identification in the sent message from the host board to the control room. Furthermore, information transmission between the modules is free as these modules utilise the unlicensed ISM band at 2.4 GHz. However, the extra cost depends on the type of long range communication technology that is used in the host board. The running cost can be reduced by reducing the frequency at which the module sends monitoring information, for example every 15 minutes instead of the three minutes given in the above example. As the monitoring and detection process do not involve people, a significant saving in operators cost is achieved.
- **Easy to control:** For the two PCBs, the host board has an RS232 interface to communicate with a computer. The remote board has JTAG port to download program from the computer as many times as needed and allow for further development of the micro-controller when needed.

For an operator in the control room, the GUI provides a consistent appearance and intuitive control buttons that are easy to operate. For instance, when users press 'receive' button, it begins to receive data, while pressing 'stop' button will end receiving data. If new information is required, 'clear' button can be pushed to clear the text in the text boxes.

- **High efficiency:** One entire monitoring loop takes only nine seconds to collect all the sensing data from the surrounding environment. The delay of data transmission is small and can be ignored. The GUI displays the real time information received from the host board.

**Table 1** Measured sensory information from the host board over seven days at three time intervals a day

<i>Date</i>	<i>Time</i>	<i>Temp.</i> °C	<i>Humi.</i> %	<i>W/speed</i> mph	<i>W/dir</i> <i>rel. to N</i>	<i>GPS loc.</i>
1st June	9:00 am	13.32	65.13	44.71	194.11	34° 55.9947' S 138° 36.2265' E
	12:30 pm	15.25	64.71	46.22	235.38	34° 55.9932' S 138° 36.2298' E
	3:00 pm	14.62	62.39	12.53	273.28	34° 55.9955' S 138° 36.2237' E
2nd June	9:00 am	11.89	75.32	16.51	22.92	34° 55.9950' S 138° 36.2165' E
	12:30 pm	17.82	65.96	9.55	25.2	34° 55.9891' S 138° 36.2122' E
	3:00 pm	16.11	61.33	15.81	17.81	34° 55.9897' S 138° 36.2147' E
3rd June	9:00 am	12.35	69.23	7.58	202.76	34° 55.9921' S 138° 36.2243' E
	12:30 pm	17.11	54.81	4.82	132.15	34° 55.9922' S 138° 36.2231' E
	3:00 pm	16.59	46.36	1.59	238.14	34° 55.9986' S 138° 36.2239' E
4th June	9:00 am	14.58	60.18	9.61	133.42	34° 55.9954' S 138° 36.2234' E
	12:30 pm	17.12	52.72	9.36	181.33	34° 55.9961' S 138° 36.2229' E
	3:00 pm	17.33	53.16	3.24	258.05	34° 55.9951' S 138° 36.2228' E
5th June	9:00 am	12.38	67.21	20.82	148.53	34° 55.9948' S 138° 36.2236' E
	12:30 pm	15.27	54.39	22.47	160.69	34° 55.9950' S 138° 36.2233' E
	3:00 pm	15.59	54.11	17.68	137.71	34° 55.9942' S 138° 36.2231' E

**Table 1** Measured sensory information from the host board over seven days at three time intervals a day (continued)

<i>Date</i>	<i>Time</i>	<i>Temp.</i> °C	<i>Humi.</i> %	<i>W/speed</i> mph	<i>W/dir</i> rel. to N	<i>GPS loc.</i>
6th June	9:00 am	12.46	63.82	25.69	165.28	34° 55.9936' S 138° 36.2228' E
	12:30 pm	14.71	52.06	8.30	167.02	34° 55.9945' S 138° 36.2233' E
	3:00 pm	15.09	47.11	16.92	212.77	34° 55.9940' S 138° 36.2229' E
7th June	9:00 am	13.09	59.23	46.37	178.24	34° 55.9943' S 138° 36.2226' E
	12:30 pm	16.82	49.96	45.81	166.9	34° 55.9939' S 138° 36.2231' E
	3:00 pm	14.75	51.62	38.49	160.28	34° 55.9935' S 138° 36.2232' E

**Table 2** System power consumption

<i>Board and state</i>	<i>Total power dissipation</i>
Host board and receiving data	180 mW
Host board and ideal	0.1 mW
Remote board and transmitting data	880 mW
Remote and ideal	170 mW

## 6 Conclusions

In this paper, a bushfire monitoring and detection device using ZigBee technology was proposed. Four sensory information are collected, namely temperature, humidity, wind speed, and wind direction. This information can be used to judge the environment in and around a house and decide if there is a fire or not. The monitoring message is sent every three minutes in normal mode, and 30 seconds in the case of a bushfire or fire. At the control room end, a MATLAB GUI provides a consistent appearance, with intuitive control buttons. The system is able to provide pre-alarm message of potential bushfires or fire. In future, this system could be improved in several aspects. For instance,

- 1 the wind direction device can be improved to remove the dead zone by using another potentiometer to cover the dead zone
- 2 the ZigBee module can be used to program and update the firmware of the microcontroller

- 3 a ZigBee module with a longer range can be used to cover a larger area
- 4 an ad hoc network that contains multiple spots of XBee modules can be designed to achieve a longer-range communication.

In addition, these modules can be linked to a GPRS network to cover a much larger area if needed. This will bring the benefits of both mobile network and internet in collecting data from different sources in a similar way to distributed sensory network.

### Acknowledgements

The authors would like to acknowledge the assistance of Mr. Pavel Simcik and Mr. Matthew Trinkle from the School of Electrical and Electronic Engineering in the University of Adelaide for providing the microcontroller development kits and helpful suggestions. In addition, we would like to thank Mr. Zhe Wang for looking into the solar panel specification and helped with the decision of purchasing one.

### References

- Australia Parliament, House of Representatives Select Committee on the Recent Australian Bushfires (2003) *A Nation Charred: Inquiry Into the Recent Australian Bushfires*, The Parliament of the Commonwealth of Australia, Canberra ACT 2601, Australia, ISBN 0-642-78445-0.
- Campbell Scientific Inc. (2001) *Model 014.A Met One Wind Speed Sensor Instruction Manual*, available at <http://www.campbellsci.com/documents/manuals/014a.pdf> (accessed on the 18 April 2009).
- Commonwealth of Australia (2001) *Economic Costs of Natural Disasters in Australia*, ISBN 0-642-45633-Xs.
- Fastrax Ltd. (2004) *uPatch02 GPS Receiver Module*, available at <http://www.fastraxgps.com/showfile.cfm?guid=2elbld34-08e6-44df-80df-16ee06dc4df6> (accessed on 18 April 2009).
- Ganewatta, G. and Handmer, J. (2006) *Bushfire Management: Why, Where and How Economics Matter?*, Brisbane, Australia, available at <http://www.griffith.edu.au/conference/bushfire2006/pdf/bushfire-management.pdf> (accessed on 18 of April 2009).
- Gomes, J. (2006) 'Forest fires in Portugal: how they happen and why they happen', *International Journal of Environmental Studies*, Vol. 63, No. 2, pp.109–119.
- Jhamtani, H. (1998) 'Forest and land fires in Indonesia: an evaluation of factors and management efforts', in A. Nugroho, H. Miyakawa, Y. Matsui, Y. Sato, C. Chan-drsekharan, E. Efransjah and M. Kuswanda (Eds.): *Tropical Forest Fire: Prevention, Control, Rehabilitation, and Trans-boundary Issues*, pp.363–384, International Tropical Timber Organization, Jakarta, Jakarta, Indonesia.
- Kaval, P. (2009) 'Perceived and actual wildfire danger: an economic and spatial analysis study in Colorado (USA)', *Environmental Management*, Vol. 90, No. 5, pp.1862–1867.
- MaxStream Inc. (2007) *XBee™/XBee-PRO™ OEM RF Modules Data Sheet*, available at <http://www.rev-ed.co.uk/docs/XBE001.pdf> (accessed on 18 April 2009).
- National Marine Electronics Association Standard (1994) Nmea-0183.
- Roberts, B. and McMahon, S. (2009) 'Coroner revises victim numbers for disaster', available at [News.com.au](http://News.com.au).

- Shell Solar (2007) *Shell STIO-Photovoltaic Solar Module*, available at <http://www.solarelectricsupply.com/pdf/shell/Shell-ST10.pdf> (accessed on 18 April 2009).
- Texas Instruments Incorporated (2006) *MSP430x15x MSP430x16x, MSP439x161x Mixed Signal Micro-controller*, available at <http://focus.ti.com/lit/ds/symlink/msp430f1611.pdf> (accessed on 18 April 2009).
- The Sensirion Company (2004) *High Precision Humidity Sensor SHT15: First Digital Humidity Sensor*, available at <http://www.sensirion.com/images/getFile?id=25> (accessed on 18 April 2009).
- US Fire Administration and National Fire Data Center (2007) *Fire in the United States 1995–2004*, Technical report, FA-311.
- Westerling, A., Hidalgo, H., Cayan, D. and Swetnam, T. (2006) 'Increases in Western US forest wildfire associated with warming and advances in the timing of spring', *Science*, Vol. 313, No. 5789, pp.940–943.